

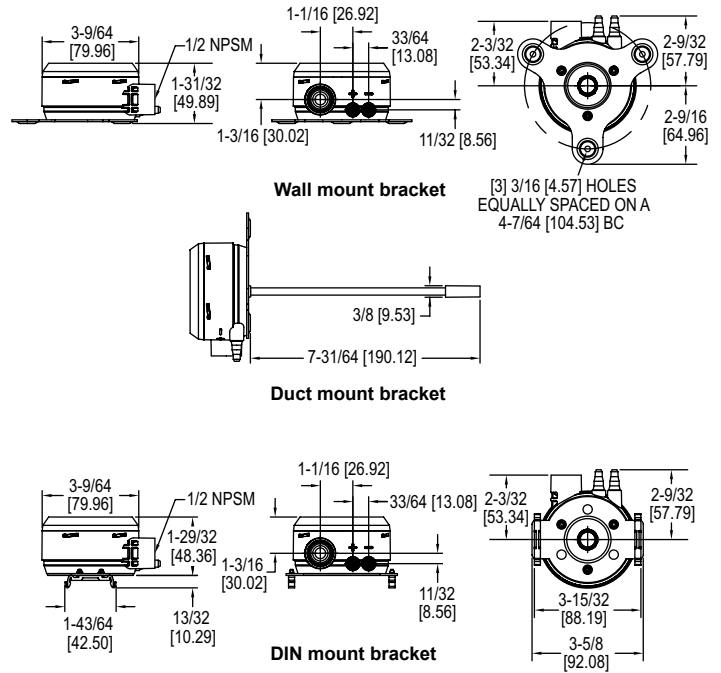

Series MSX Magnesense® Differential Pressure Transmitter

Specifications - Installation and Operating Instructions



The **Series MSX Magnesense® Differential Pressure Transmitter** combines the stability and versatility of the original Series MS2 Magnesense® II transmitter for use in building control applications. The MSX simplifies the ordering process to deliver the desired configuration, which reduces product setup time. Pressure ranges are available in Pa, mm w.c., and in w.c. All pressure ranges can be configured in unidirectional or bidirectional modes, providing a total of 32 ranges. The MSX transmitter can provide a linear pressure output or a linear velocity output with the square root extraction from the transmitter. Additional parameters have been included to expand the square root capability to calculate flow. Dual voltage and milliamp output signals can be used to provide both control and equipment output signal verification.

INSTALLATION

Surface Mounting:

Mount the transmitter on a vertical surface. The pressure sensor measurement is unaffected by orientation, but it is recommended the unit be mounted with the connections facing down to prevent moisture from entering either the pressure ports or the electrical cable entry. Attach the mounting flange to a flat surface using #8 x 1/2" pan head sheet metal screws. Do not over tighten.

Duct Mounting (Universal Model Required):

Mount the transmitter away from fans, corners, heating and cooling coils and other equipment that will affect the measurement of the pressure.

1. To mount the transmitter, drill a .562" (12.70 mm) diameter hole into the duct.
2. Screw duct probe into back of housing. Insert transmitter probe into the duct.
3. Mark location of mounting holes on duct using mounting flange as template. Drill holes.
4. Attach mounting flange to duct with #8 x 1/2" pan head sheet metal screws. Do not over tighten screws.
5. Place the included cap on the exterior positive pressure port.

The Universal model can also be used as a standard wall mount transmitter. In this mode, do not use the duct probe and plug the port on the backside of the transmitter with the included plug.

SPECIFICATIONS

<p>Service: Air and non-combustible, compatible gases.</p> <p>Wetted Materials: Consult factory.</p> <p>Accuracy: ±1% FSO.</p> <p>Stability: ±1% FSO/year.</p> <p>Temperature Limits: -4 to 158°F (-20 to 70°C).</p> <p>Pressure Limits: Ranges 0 and 1: 3.6 psi max operation, 6 psi burst; Ranges 2, 3 and 4: 6 psi max operation, 6 psi burst.</p> <p>Power Requirements: 10-36 VDC (2-wire), 17-36 VDC or isolated 21.6-33 VAC (3-wire).</p> <p>Output Signals: 4-20 mA (2-wire); 0-10 V or 0-5 V selectable (3-wire).</p> <p>Response Time: Instantaneous (default) or 3 s (selectable).</p> <p>Zero and Span Adjustments: Digital push-button.</p>	<p>Loop Resistance: Current output: 0-1250 Ω max; Voltage output: min. load resistance 1 k Ω.</p> <p>Current Consumption: 21 mA max continuous.</p> <p>Electrical Connections: 4-wire removable European style terminal block for 16 to 26 AWG.</p> <p>Electrical Entry: 1/2" NPS thread.</p> <p>Display (optional): 4 digit LCD.</p> <p>Process Connections: 1/8", 3/16", 1/4", 5 mm, and 6 mm ID flexible tubing.</p> <p>Enclosure Rating: NEMA 4X (IP66); UL 2043 (Plenum); UL94 V-0.</p> <p>Mounting Orientation: Pressure sensor measurement unaffected by orientation.</p> <p>Weight: 8.0 oz (230 g).</p> <p>Compliance: CE.</p>
--	--

OPTIONS

Range	in w.c.	Pa low	Pa high	mm w.c.
Range 0	0.1	25	60	2.5
	0.15	30	75	5
	0.25	40	100	10
	0.5*	50	125*	12*
Range 1	0.1	25	100	2.5
	0.25	40	150	5
	0.5	50	160	10
	1*	60	250*	25*
Range 2	1	250	600	25
	2	300	750	50
	3	400	1000	100
	5*	500	1250*	125*
Range 3	10	1000	3000	250
	15	1500	4000	350
	25	2000	5000	500
	28*	2500	7000*	700*
Range 4	1	250	1000	25
	5	300	2000	125
	10	400	3000	250
	15*	500	4000*	400*

*Indicated values are the positive full scale output values per range. **Note:** Ranges indicated in the table are the high end of the set range. All ranges have a low end pressure value of 0.

ELECTRICAL

The MSX transmitter utilizes a **2-wire 4-20 mA Current Output**, or a **3-wire 0-5 V / 0-10 V Voltage Output**. It is also capable of **Simultaneous Current and Voltage Output**. The power and signals interconnect via a removable European-style four conductor terminal block.

NOTICE If equipped, the LCD must be removed before wiring. Pull the LCD directly away from the product to remove. Reinstall the LCD after wiring is completed.

2-Wire 4-20 mA Current Output

CAUTION DO NOT EXCEED SPECIFIED SUPPLY VOLTAGE RATINGS. PERMANENT DAMAGE NOT COVERED BY WARRANTY WILL RESULT. SIMULTANEOUS OUTPUTS ARE NOT DESIGNED FOR AC VOLTAGE OPERATION.

The connections to the transmitter are made through terminals VDC and COM on the terminal block as shown in Figure 1. The terminal block is removable and each of the terminals are labeled next to the terminal block on the circuit board. Polarity is indicated by VDC and COM. See Figure 1.

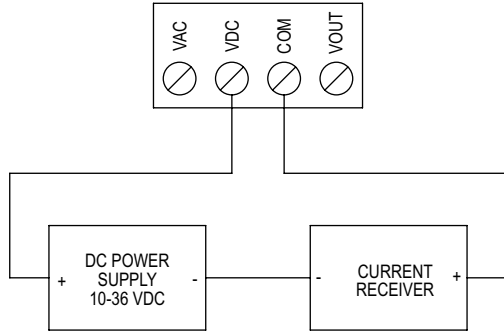

Figure 1

The maximum receiver load resistance (R_L) for a given power supply voltage (V_{PS}) is defined by the formula:

$$R_L = \frac{V_{PS} - 10.0}{20 \text{ mA DC}}$$

Shielded 2-wire cable is recommended for control loop wiring. Ground the shield at the power supply end only.

The receiver may be connected to either the negative or positive side of the loop, whichever is most convenient. Should polarity of the transmitter or receiver be inadvertently reversed, the loop will not function properly but no damage will be done to the transmitter.

The maximum length of connecting wire between the transmitter and the receiver is a function of wire size and receiver resistance. That portion of the total current loop resistance represented by the resistance of the connecting wires themselves should not exceed 10% of the receiver resistance. For extremely long runs (over 1,000 feet), it is desirable to select receivers with lower resistances in order to keep the size and cost of the connecting leads as low as possible. In installations where the connecting run is no more than 100 feet, you can use a connecting lead wire as small as No. 22 ga.

3-Wire 0-10 V and 0-5 V Voltage Output

CAUTION DO NOT EXCEED SPECIFIED SUPPLY VOLTAGE RATINGS. PERMANENT DAMAGE NOT COVERED BY WARRANTY WILL RESULT.

The terminal block is removable and each of the terminals are labeled next to the terminal block on the circuit board. Positive polarity is indicated by VOUT. AC/DC selection is made via the terminal block. If the polarity of the transmitter is inadvertently reversed, the unit will not function properly, but no damage will be done to the transmitter.

Selection of using a DC or AC power supply is made via the terminal block. See Figure 2 for DC Wiring. See Figure 3 for AC Wiring.

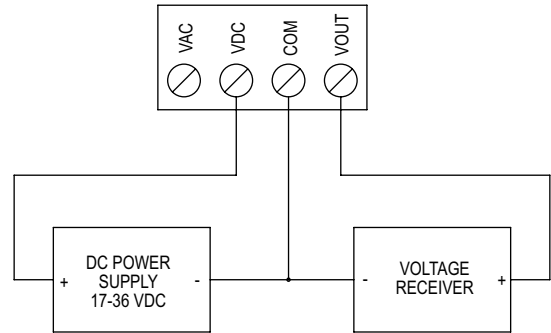

Figure 2: DC wiring

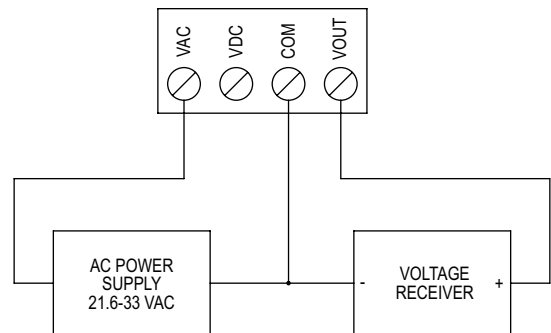

Figure 3: AC wiring

The minimum receiver load is 1 k Ω . The resistance due to the wire should be low compared to the receiver load resistance. While the voltage at the terminal block remains unchanged with a 10 mA current flow, resistive losses in the wiring do cause errors in the voltage delivered to the receiver. For a 1% accurate gage, the resistance of the wires should be less than 0.1% of the value of the receiver load resistance. This will keep the error caused by the current flow below 0.1%.

The output across VOUT and COM will be either 0-5 V, 0-10 V depending on the DIP switch setting. See **DIP Switch Settings Section** for more information.

Simultaneous Current and Voltage Output

CAUTION DO NOT EXCEED SPECIFIED SUPPLY VOLTAGE RATINGS. PERMANENT DAMAGE NOT COVERED BY WARRANTY WILL RESULT. SIMULTANEOUS OUTPUTS ARE NOT DESIGNED FOR AC VOLTAGE OPERATION.

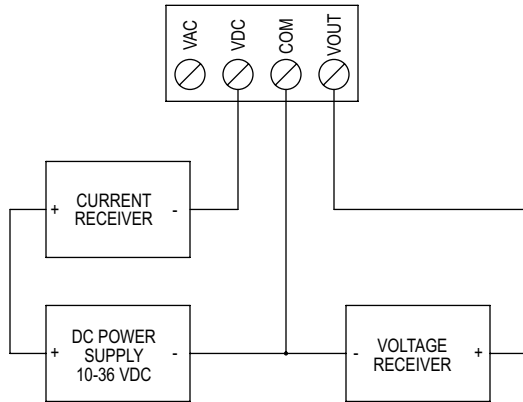

Figure 4: Simultaneous current and voltage output wiring

The terminal block is removable and each of the terminals is labeled underneath the terminal block on the circuit board. Positive polarity is indicated by VOUT. The VDC terminal and a DC power supply must be used for simultaneous current and voltage output. The voltage output and the power supply must have separate wire leads that are only joined at terminal 2 of the transmitter. Additional error may occur for the voltage output if a single wire is used or if the wires are joined at the power supply or receiver.

For the current output, the maximum allowable loop resistance (wiring + receiver resistance) is dependent on the power supply. The maximum loop voltage drop must not reduce the transmitter voltage below 17 V. The maximum loop resistance (R_{MAX}) for a given power supply voltage (V_{PS}) can be calculated using the following equation:

$$R_{MAX} = \frac{(V_{PS} - 17.0)}{20 \text{ mA DC}}$$

The equation uses 17.0 instead of 10.0 as seen in the equation earlier with Figure 1. This represents the minimum voltage supply which is higher on the simultaneous output configuration due to the requirements of the voltage outputs.

Shielded 4-wire cable is recommended for control loop wiring. Ground the shield at the power supply end only. Should the polarity of the transmitter or receiver be inadvertently reversed, the unit will not function properly, but no damage will be done to the transmitter.

For voltage outputs, the minimum receiver load is 1 k Ω . The resistance due to the wire should be low compared to the receiver load resistance. While the voltage at the terminal block remains unchanged with a 10 mA current flow, resistive losses in the wiring do cause errors in the voltage delivered to the receiver. For a 1% accurate gage, the resistance of the wires should be less than 0.1% of the value of the receiver load resistance. This will keep the error caused by the current flow below 0.1%.

The output across VOUT and COM will be either 0-5 V or 0-10 V depending on the DIP switch setting. See **DIP Switch Settings Section** for more information.

Power Supply

Refer to the following tables for the required supply rating.

Current Output	
Supply Voltage	10-36 VDC
Loop Resistance	0-1250 Ω

Voltage Output	
Supply Voltage	17-36 VDC
	21.6 to 33 VAC isolated
Minimum Output Load Resistance	1000 Ω

DIP SWITCH SETTINGS

DIP switch settings are marked directly on the PCBA as shown in Figure 5. Switches are factory-set, based on the order configuration. You can also use a small screwdriver or pen to change the position of the switches.

NOTICE Figure 5 is a depiction of a 5 in w.c. pressure board. Other pressure boards, while similar, will vary from the below.

WARNING There are no hazardous voltages if supplied power is within the specified range. However, it is a good idea to shut control systems down while changing DIP switches to prevent erratic control system behavior.

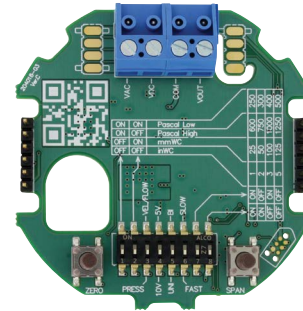

Figure 5: 5 in w.c. pressure board

Key To DIP Switch Settings

Switches are numbered 1 to 8 beginning on the left.

DIP Switches 1 and 2 - Unit of Measure Selection

DIP Switches 1 and 2 work as a pair to select the unit of measure.

PRESSURE UNIT SELECTION - DIP SWITCH 3 IS OFF (DOWN)		
DIP Switch 1	DIP Switch 2	Unit of Measure
ON	ON	Pa (low ranges)
ON	OFF	Pa (high ranges)
OFF	ON	mm w.c.
OFF	OFF	in w.c.

VELOCITY/FLOW UNIT SELECTION - DIP SWITCH 3 IS ON (UP)		
DIP Switch 1	DIP Switch 2	Unit of Measure
ON	ON	m ³ /hr (Flow)
ON	OFF	m/s (Velocity)
OFF	ON	CFM (Flow)
OFF	OFF	FPM (Velocity)

DIP Switch 3 - Pressure vs Velocity/Flow Mode of Operation

DIP Switch 3 toggles between pressure output vs velocity or flow output.

- When the switch is in the OFF or down position, the device is in Pressure Mode.
- When the switch is in the ON or up position, the device is in Velocity/Flow Mode.

DIP Switch 4 - Voltage Output Range

Voltage output range can be either 0-10 V or 0-5 V depending on the position of DIP Switch 4.

- When the switch is in the OFF or down position, the output will be 0-10 V.
- When the switch is in the ON or up position, the output will be 0-5 V.

DIP Switch 5 - Unidirectional vs Bidirectional Output

DIP Switch 5 can be set to measure pressure in one direction (unidirectional) or in both directions (bidirectional).

- When the switch is in the OFF or down direction, the transmitter will be set for unidirectional and will be 0 based (i.e. 0 to 5 in w.c.).
- When the switch is in the ON or up position, the transmitter will be set for bidirectional and will be ± the maximum of the selected range (i.e. ±5 in w.c.).

DIP Switch 6 - Response Time Selection

DIP Switch 6 toggles to select the desired response time.

- When the switch is in the OFF or down direction, the transmitter response time will be instantaneous.
- When the switch is in the ON or up direction, the response time will be 3 seconds.

DIP Switches 7 and 8 - Maximum Range Selection (Pressure)

DIP switches 7 and 8 work as a pair to select the maximum range output of the transmitter. Use the tables below to navigate pressure range selection. Alternatively, if using the device for velocity and flow, proceed to the next section.

RANGE 0 PRESSURE RANGE SELECTIONS					
DIP Switch 7	DIP Switch 8	Pa (set 1)	Pa (set 2)	mm w.c.	in w.c.
ON	ON	25	60	2.5	0.1
OFF	ON	30	75	5	0.15
ON	OFF	40	100	10	0.25
OFF	OFF	50	125	12	0.5

RANGE 1 PRESSURE RANGE SELECTIONS					
DIP Switch 7	DIP Switch 8	Pa (set 1)	Pa (set 2)	mm w.c.	in w.c.
ON	ON	25	100	2.5	0.1
OFF	ON	40	150	5	0.25
ON	OFF	50	160	10	0.5
OFF	OFF	60	250	25	1

RANGE 2 PRESSURE RANGE SELECTIONS					
DIP Switch 7	DIP Switch 8	Pa (set 1)	Pa (set 2)	mm w.c.	in w.c.
ON	ON	250	600	25	1
OFF	ON	300	750	50	2
ON	OFF	400	1000	100	3
OFF	OFF	500	1250	125	5

RANGE 3 PRESSURE RANGE SELECTIONS					
DIP Switch 7	DIP Switch 8	Pa (set 1)	Pa (set 2)	mm w.c.	in w.c.
ON	ON	1000	3000	250	10
OFF	ON	1500	4000	350	15
ON	OFF	2000	5000	500	25
OFF	OFF	2500	7000	700	28

RANGE 4 PRESSURE RANGE SELECTIONS					
DIP Switch 7	DIP Switch 8	Pa (set 1)	Pa (set 2)	mm w.c.	in w.c.
ON	ON	250	1000	25	1
OFF	ON	300	2000	125	5
ON	OFF	400	3000	250	10
OFF	OFF	500	4000	400	15

DIP Switches 7 and 8 - Maximum Range Selection (Velocity/Flow)

DIP switches 7 and 8 work as a pair to select the maximum range output of the transmitter. Use the tables below to navigate velocity and flow range selection.

RANGE 0 PRESSURE RANGE SELECTIONS					
DIP Switch 7	DIP Switch 8	m³/hr (Flow)	m/s (Velocity)	CFM (Flow)	FPM (Velocity)
ON	ON	1700	5	850	850
OFF	ON	2700	8	1250	1250
ON	OFF	3700	11	2000	2000
OFF	OFF	4800	14	2800	2800

RANGE 1 PRESSURE RANGE SELECTIONS					
DIP Switch 7	DIP Switch 8	m³/hr (Flow)	m/s (Velocity)	CFM (Flow)	FPM (Velocity)
ON	ON	2500	7.5	1250	1250
OFF	ON	3300	10	2000	2000
ON	OFF	5200	15	2800	2800
OFF	OFF	6800	20	4000	4000

RANGE 2 PRESSURE RANGE SELECTIONS					
DIP Switch 7	DIP Switch 8	m³/hr (Flow)	m/s (Velocity)	CFM (Flow)	FPM (Velocity)
ON	ON	6800	20	4000	4000
OFF	ON	8600	25	5600	5600
ON	OFF	11800	35	6900	6900
OFF	OFF	15200	45	8950	8950

RANGE 3 PRESSURE RANGE SELECTIONS					
DIP Switch 7	DIP Switch 8	m³/hr (Flow)	m/s (Velocity)	CFM (Flow)	FPM (Velocity)
ON	ON	18000	55	9000	9000
OFF	ON	23000	70	12000	12000
ON	OFF	30000	90	15000	15000
OFF	OFF	36000	107	20000	20000

RANGE 4 PRESSURE RANGE SELECTIONS					
DIP Switch 7	DIP Switch 8	m³/hr (Flow)	m/s (Velocity)	CFM (Flow)	FPM (Velocity)
ON	ON	7000	20	4000	4000
OFF	ON	15000	45	9000	9000
ON	OFF	21000	64	12000	12000
OFF	OFF	26000	78	15000	15000

CALIBRATION

There is a 3 second delay from the time the zero or span calibration buttons are released until the time that the change in calibration takes place. This delay is used to prevent stress related offsets on the lower ranges.

Zero Calibration

The zero calibration can be set by applying zero pressure to both of the pressure ports and pressing the zero button for 3 seconds. If the LCD display is present, the display will read ZERO and then sequence back to the home display.

Span Calibration

NOTICE For a positive span, apply pressure to the positive "+" port.

The span calibration function allows the pressure value to be adjusted so that the currently applied pressure is the maximum configured pressure. This will in turn set the maximum analog output at the set pressure. It is recommended that the ZERO function be applied before performing a span. Apply the maximum desired pressure to the device, press and hold span for 3 seconds. If the LCD display is present, SPAN is displayed. The span function will be processed 3 seconds after the span button is released.

LCD DISPLAY

The LCD comes with a housing cover, which contains a window. The display plugs into the pins on top of the circuit board. The LCD is 180° rotatable so that it will read properly if the device must be mounted with the connections facing up.

The following error messages will appear if an LCD is present and the device is in an error state.

LCD ERROR MESSAGES	
Error Code	Message
OVER	The applied pressure is 3% greater than the selected output high value causing an Over Range Error.
UNDR	The applied pressure is 1% less than the selected output low value causing an Under Range Error.
FAIL	When the span button is pressed, the pressure value is out of the range to allow a correct setting.
ER 1	The pressure applied to the sensor is beyond its ability to read.
ER 2	The pressure sensor is communicating but reporting an internal error.
ER 3	The pressure sensor is not communicating.
ER 4	The stored user settings are invalid.
ER 5	The stored factory settings are invalid.
ER 6	Non-volatile user memory has failed.
ER 7	Non-volatile factory memory has failed.

PROGRAM MENU

Home Menu

During normal operation, the display will be in the Home Menu and will display the current measured pressure and the engineering units.

MAINTENANCE/REPAIR

Upon final installation of the Series MSX, no routine maintenance is required. The Series MSX is not field serviceable and should be returned if repair is needed. Field repair should not be attempted and may void warranty.



This symbol indicates waste electrical products should not be disposed of with household waste. Please recycle where facilities exist. Check with your Local Authority or retailer for recycling advice.

WARRANTY/RETURN

Refer to "Terms and Conditions of Sale" in our catalog and on our website. Contact customer service to receive a Return Materials Authorization (RMA) number before shipping the product back for repair. Be sure to include a brief description of the problem plus any additional application notes.

MSX MAIN UI AND PRESSURE FLOWCHART

MENU LEGEND

- ⓪ PRESS ZERO/VALUE BUTTON
- Ⓛ PRESS SPAN/DIGIT BUTTON
- Ⓜ PRESS EITHER ZERO/VALUE OR SPAN/DIGIT BUTTON
- Ⓜ HOLD ZERO/VALUE BUTTON
- Ⓛ HOLD SPAN/DIGIT BUTTON
- Ⓜ HOLD BOTH ZERO/VALUE AND SPAN/DIGIT BUTTON

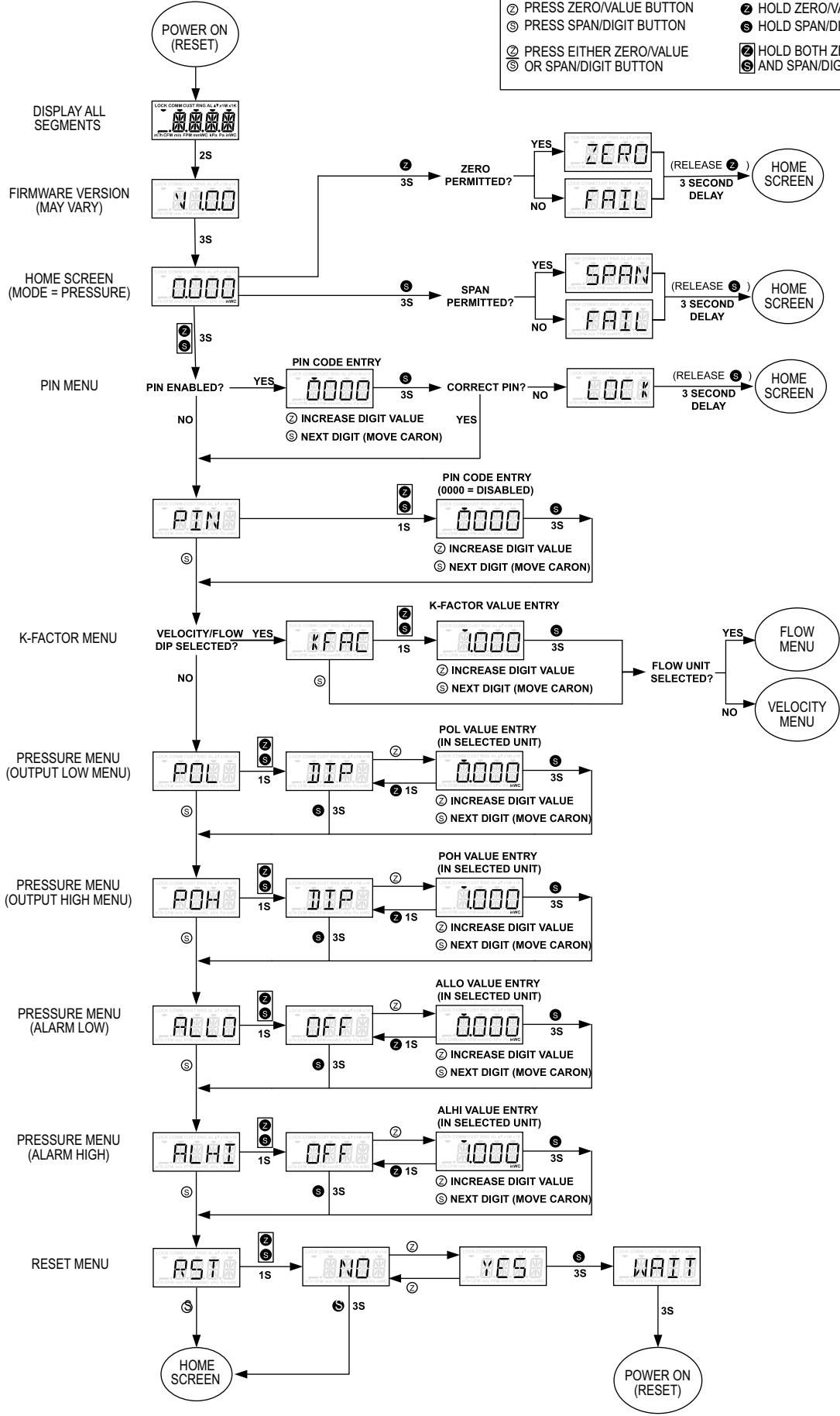

MSX VELOCITY SETTINGS FLOWCHART

MENU LEGEND

- ⓪ PRESS ZERO/VALUE BUTTON
- ⓫ PRESS SPAN/DIGIT BUTTON
- ⓬ PRESS EITHER ZERO/VALUE OR SPAN/DIGIT BUTTON
- Ⓜ HOLD ZERO/VALUE BUTTON
- Ⓨ HOLD SPAN/DIGIT BUTTON
- Ⓩ HOLD BOTH ZERO/VALUE AND SPAN/DIGIT BUTTON

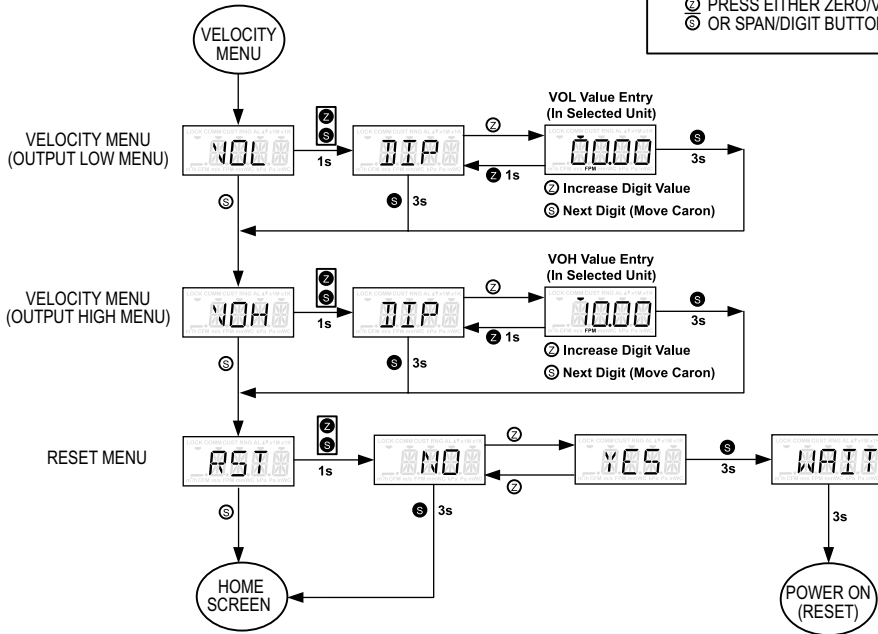

MSX FLOW SETTINGS FLOWCHART

